



PRODUCT CATALOG
2010

Flotation

GLASS INSTRUMENT HOUSINGS

Deep Sea Glass Spheres

Deep sea glass spheres are a unique, reliable, cost-effective method for flotation and the housing of electronic instruments in the marine environment. Teledyne Benthos is the world's leading manufacturer of deep sea glass spheres and instrument housings. Ongoing improvements ensure their high reliability in extreme environments. Advanced assembly techniques and the patented VacuSealed® closure method result in high quality, long-life spheres. Teledyne Benthos pressure tests every sphere prior to shipment, assuring their integrity in the field.

Deep sea glass spheres are superior to other types of flotation and instrument housing for several reasons: they are transparent, lightweight, inexpensive, corrosion resistant, easily handled, extremely strong, and non-polluting. As a result, they are preferred by oceanographers worldwide and are backed by over 40 years of experience in deep sea technology.



INNOVATIVE UNDERSEA SYSTEMS TECHNOLOGY



**TELEDYNE
BENTHOS**

A Teledyne Technologies Company

Glass Spheres & Instrument housings



Teledyne Benthos' patented VacuSealed® glass floats and instrument housings are manufactured from precision-molded spheres to exact specifications. The edge of each hemisphere is ground flat to extreme tolerances. When used for flotation the hemispheres are matched, mated, and then evacuated to an absolute internal air pressure of less than 0.3 atmospheres. After evacuation, a sealant and protective tape are applied around the equator. Spheres sealed in this method are nearly impossible to open due to the force exerted upon them by the atmospheric pressure. In the case of the 43.2 cm (17 in) diameter float, this force is in excess of 880 kg (2000 lbs).

Vacuum Ports

A titanium vacuum port (Model 204-VPT) can be installed in a glass instrument housing to facilitate opening and closing the sphere. The vacuum port option is recommended for any housing that will be opened frequently.

Specifications

Type	Low expansion borosilicate
Thermal Coefficient of Expansion	38x10 ⁻⁷ /°C
Specific Gravity	2.22
Young's Modulus	62 GPa (9x10 ⁶ P.S.I.)
Poisson's Ratio	0.20
Refractive Index	1.48
Thermal Conductivity	0.0023 calorie cm/cm ² sec°C
Specific Heat	0.18 calorie/g°C

Dimensions, Weight, and Depth Data	Sphere Model 2040-10V	Sphere Model 2040-13V*	Sphere Model 2040-17V
Outside Diameter	25.4 cm (10 in)	33 cm (13 in)	43.2 cm (17 in)
Inside Diameter	23.6 cm (9.3 in)	30.5 cm (12 in)	40.4 cm (15.9 in)
Weight in Air	4.1 kg (9 lbs)	9.07 kg (20 lbs)	17.7 kg (39 lbs)
Net Bouyancy	4.5 kg (10 lbs)	10.4 kg (23 lbs)	25.4 kg (56 lbs)
Depth Rating	9000 m (29,500 ft)	9000 m (29,500 ft)	6700 m (22,000 ft)

*13" spheres available with improved optical transmission profiles, low potassium and low photonic radiation.

Note: All prices listed in U.S. dollars

Flotation Spheres

Part Number	Description
C-204-40.....	2040-10V; Glass Flotation Sphere - 10" (25.4 cm) 4.5 kg (10 lbs) Approximate Net Buoyancy.
C-204-41.....	2040-13V; Glass Flotation Sphere - 13" (33 cm) 10.4 kg (23 lbs) Approximate Net Buoyancy.
C-204-42.....	2040-17V; Glass Flotation Sphere - 17" (43.2 cm), 25.4 kg (56 lbs) Approximate Net Buoyancy.

Instrument Housing

C-204-43.....	2040-10H; Glass Instrument Housing-10" (25.4 cm)
C-204-44.....	2040-13H; Glass Instrument Housing-13" (33 cm)
C-204-45.....	2040-17H; Glass Instrument Housing-17" (43.2 cm)

Glass Spheres & Instrument housings

Hard Hats

Part Number	Description
C-204-50	204H-10; Hard Hat Housing for 10" Sphere
C-204-99	204-SRO-13; Super Ribbed Hard Hat Housing for 13" Sphere
C-204-49-1	204H-17; Standard Hard Hat Housing for 17" Spheres
C-204-49-2	204HR-17; Ribbed Hard Hat Housing for 17" Sphere
C-204-49-3	204-SRO-17; Super Ribbed Octagonal Flange Hard Hat Housing for 17" Sphere
C-204-49-4	204-SRM-17; Super Ribbed Mooring Flange Hard Hat Housing for 17" Sphere

Bright yellow, neutrally buoyant, polyethylene hard hats are available for glass protection, storage, and ease of handling. Hard hats consist of two flanged units bolted together with stainless steel hardware. Flanges can be bolted to a mounting framework, wire clamp, or chain section on a mooring line.



Standard
204H



Ribbed
204HR



Super Ribbed
204-SRO/204-SRM

Spares & Accessories

Part Number	Description
C-189-18-5	204N-17; Nylon Net Bag for 17" Spheres
0900-024	204-SS; Sealant Strip for Glass Spheres. 9.1 M (25 Ft. Roll)
0903-013	204-T; Tape; Black for Glass Spheres. 30.5 M (100 Ft Roll) Wide Version

Instrument Housing Options

Part Number	Description
B-204-123-1	2045-78-N; Single Penetrator, Uninstalled
B-204-78	Single Neoprene Penetrator, Installed
B-204-86	204-VPT; Titanium Vacuum Port, Installed
B-204-48-1	204-DHO; Glass Hole Drilling to 1/2" Width Ground Flat
B-204-48-2	204-DHO; Glass Hole Drilling Greater Than 1/2" Width Ground Flat



Drill Hole Instruction Sheet

When measuring for holes, orient hemispheres as shown.

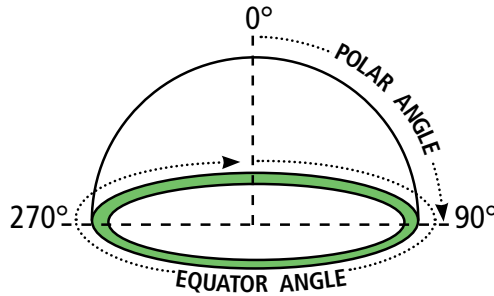
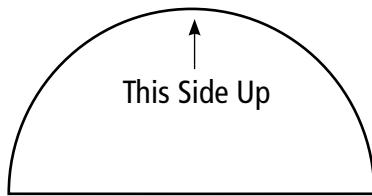

Measure along the Polar and Equator angles to determine the exact location of all holes to be drilled in each glass sphere. Record all necessary information in the grids below.

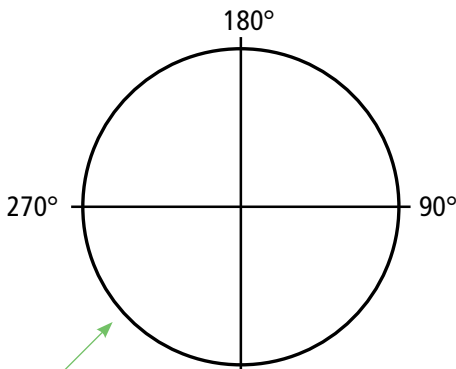

Top view of hemispheres

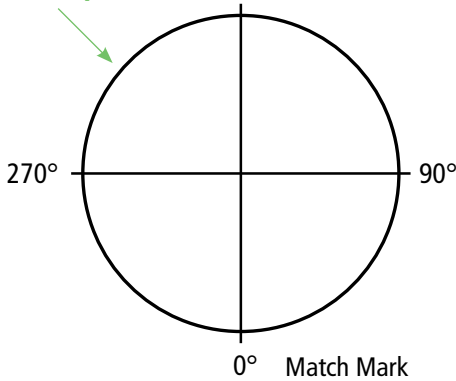

TOP HEMISPHERE								
Hole Number	A	B	C	D	E	F	G	H
Equator Angle								
Polar Angle								
Hole Type								

BOTTOM HEMISPHERE								
Hole Number	1	2	3	4	5	6	7	8
Equator Angle								
Polar Angle								
Hole Type								

Customer: _____ Date: _____

Revision: _____

Sales Order: _____ Ship Date: _____ Quantity: _____ Size: _____

Recommended Polar Angle for Penetrators for Hard Hat Clearance				
10" H 25	13" SRO 30	17" H 30	17" HR N.A.	17" SR 25

Typical Vacuum Port Positions	
XT-6000-10	E=180 P=45, top hemi, per B-500-3
XT-6000-17	E=0 P=25, top hemi, per B-500-7
TR-6000	E=135 P=25, per B-210-428

Hole Type	Standard Applications	Drill Diameter
1	Vacuum Port, 3/16"	.203"
2	XT/TR Transducer	.281"
3	Bulkhead, 7/16", Brass	.453"
4	Bulkhead, 7/16", Titanium	.438"
5	Single Pin Penetrator	.156"

Special Applications		
6		
7		
8		

NOTE: — All customer supplied penetrators must have 1" stems and be furnished with dummy plugs and hardware.
 — When shipping penetrators to Teledyne Benthos, please reference purchase order number and/or sales order number.

Maximum polar angle is 50°

Glass Spheres & Instrument Housings

Dimensions and Weight in Air

Dimensions shown below	A		B		C		D		E		F		Air Weight	
Model	cm	in	cm	in	cm	in	cm	in	cm	in	cm	in	kg	lbs
204H-10	35.6	14.0	6.4	2.5	29.2	11.5	31.8	12.5					0.74	1.62
204H-17	55.9	22.0	12.7	5.0	48.3	19.0	49.5	19.5					2.95	6.50
204HR-17	54.6	21.5	38.1	15.0	49.5	19.5	35.8	14.1	5.1	2.0	43.2	17.0	3.29	7.25
204-SRO-13	48.3	19.0	12.7	5.0	40.6	16.0	43.2	17.0					2.50	5.50
204-SRO-17	61.0	24.0	12.7	5.0	53.3	21.0	55.9	22.0					3.63	8.00
204-SRM-17	55.9	22.0	38.1	15.0	51.8	20.4	35.0	13.7	3.8	1.5	43.7	17.2	3.74	8.25

(neutrally buoyant in water)

204H-10 and 17 Standard Hard Hat

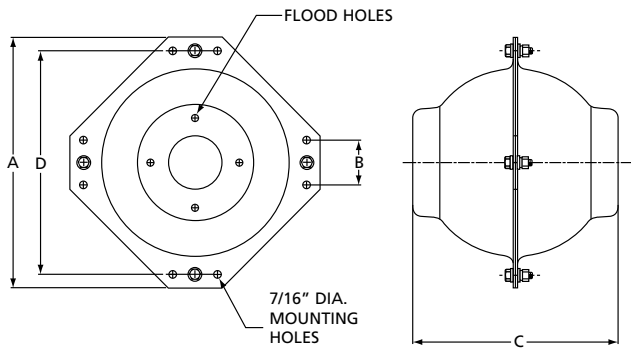

204HR-17 Ribbed Hard Hat

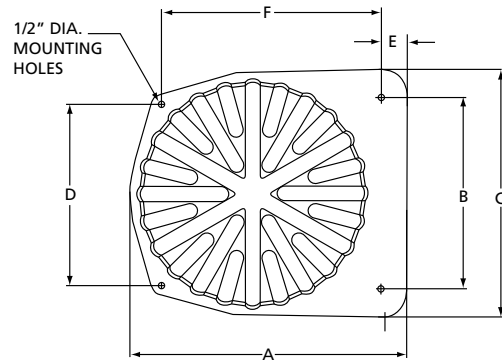

204-SRO-13 and 17 Super Ribbed Octagonal Hard Hat

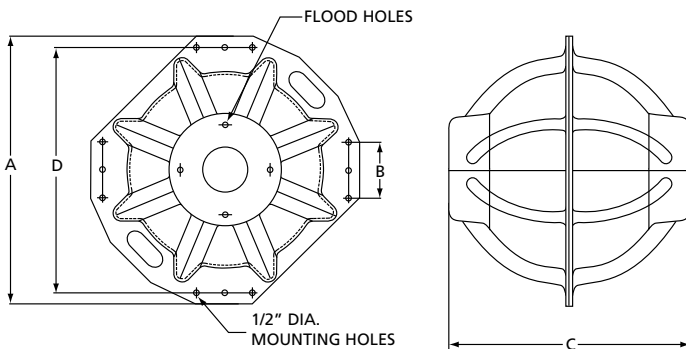

204-SRM-17 Super Ribbed Mooring Hard Hat

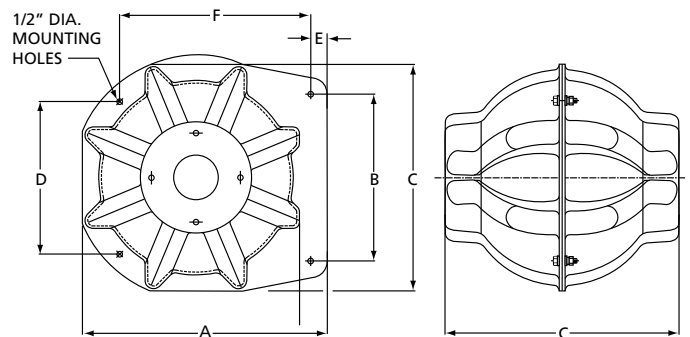

Miscellaneous

Terms & Conditions for Sale

Revision February 27, 2009

1. DEFINITIONS

"Seller" means Teledyne Benthos, Inc., a business unit of Teledyne Technologies Incorporated. "Buyer" means the legal entity purchasing Goods from Seller. "Goods" means the products offered by Seller and/or purchased by Buyer. "Offer" means any quote, proposal, or offer to sell Goods provided by Seller to Buyer. "Order" means any purchase order or similar instrument issued by Buyer to Seller to purchase Goods. Seller and Buyer are sometimes referred to herein individually as a "Party" and collectively as the "Parties".

2. ACCEPTANCE

The terms and conditions included in this "Terms and Conditions of Sale" document (hereinafter, this "Agreement") apply to all Offers made by Seller to Buyer and all Buyer's Orders accepted by Seller. Acceptance of Buyer's Orders, and any changes or amendments thereto, is expressly conditioned upon Buyer's assent to these terms and conditions. Unless specifically agreed to in writing by a duly authorized representative of Seller, Seller objects to, and is not bound by, any terms or conditions that differ from or add to the terms and conditions specified herein. Seller's failure to object to any terms and conditions or any other provisions contained in any communication from Buyer, including, but not limited to, Buyer's Orders, does not waive any of the terms and conditions specified herein. Seller's acceptance of any resulting Order or Buyer's receipt of Goods, whichever occurs first, will conclusively evidence Buyer's unconditional acceptance of these terms and conditions. A minimum Order amount of \$100.00 USD applies.

3. PRICES

Unless stated otherwise in writing by Seller, all prices are stated in U.S. Dollars and the prices offered are valid for a period of thirty (30) days from the date of Seller's Offer. The prices offered apply only to the specific quantities, specifications, and delivery schedules set forth in Seller's Offer. Any variation in quantity, specifications, or delivery schedules may necessitate a price and/or delivery schedule adjustment. Unless stated otherwise, all prices for domestic deliveries are F.O.B. Seller's place of shipment, as defined in the Uniform Commercial Code (UCC), and all prices for international deliveries are Ex-Works, as defined by INCOTERMS 2000.

4. CREDIT APPROVAL AND PAYMENT

Standard payment terms for domestic Orders are net thirty (30) days from date of Seller's invoice, subject to credit approval of Buyer by Seller. Payment terms for international orders may be cash in advance by wire transfer or an irrevocable letter of credit confirmed with Seller's bank. Credit terms, shipments, and performance of work are at all times subject to the approval of Seller's Credit Department. Each shipment is a separate and independent transaction and payment must be made by Buyer accordingly.

If, prior to shipment of Buyer's Order, Buyer fails to fulfill the terms of payment of any prior invoice submitted by Seller or, if in the opinion of Seller, Buyer's financial condition becomes impaired or unsatisfactory, Seller reserves the right to change, without notice, the terms of payment and/or delay or discontinue further shipments, without prejudice to any other available legal remedies, until past due obligations have been paid and Seller has received acceptable assurance regarding Buyer's prompt payment of future obligations. All amounts due to Seller but not paid by Buyer on the due date bear interest payable by Buyer to Seller in U.S. Dollars at a rate that is equal to the lesser of (i) one and one-half percent (1.5%) per month, or (ii) the maximum interest rate permitted under applicable law. Interest accrues on the balance of unpaid amounts as of the date on which portions of those amounts become due until the date payment is received by Seller. Buyer will also be liable to Seller for any expenses incidental to collection of past due amounts, including reasonable attorney's fees and court costs. In the event of Buyer's bankruptcy or insolvency, Seller is entitled to terminate any Order then outstanding and to receive reimbursement for termination costs and expenses as provided under Article 13, Termination for Default.

5. TAXES

The amount of any present or future sales, use, excise, import duty, or other tax applicable to the manufacture, sale, or lease of Goods will be added to the invoice and must be paid by Buyer, unless the Buyer provides Seller with a tax exemption certificate acceptable to the applicable taxing authority.

6. SHIPPING TERMS AND RISK OF LOSS

All domestic shipments by Seller are F.O.B. Seller's place of shipment, as defined in the Uniform Commercial Code. All international shipments by Seller are Ex-Works, as defined by INCOTERMS 2000. Risk of loss for Goods will transfer to Buyer upon Seller presenting Goods to carrier. If Seller prepays shipping, insurance, or other related costs, Buyer agrees to reimburse Seller promptly for the actual costs incurred by Seller plus ten percent (10%).

7. TOOLING

Unless otherwise provided by special written agreement signed by Seller and Buyer, all tooling, fixtures, equipment, tools, software, and designs produced, acquired, or used by Seller for the purposes of filling Buyer's Order remain the property of the Seller.

8. PACKING AND PACKAGING

Seller's prices for Goods include Seller's standard commercial packing and packaging. Any non-standard or special packing or packaging requirements requested by Buyer will be provided by Seller at additional cost to Buyer.

9. INSPECTION AND TESTS

All Goods manufactured by Seller are subject to Seller's standard inspection processes and, if applicable, acceptance testing at Seller's facility. Any additional requirements, including, without limitation, Buyer's source inspection or additional testing, are at Buyer's sole expense. If Seller and Buyer agree that Buyer is to inspect or provide for inspection at the place of manufacture, such inspection may not interfere unreasonably with Seller's operations and the Buyer's approval or rejection of Goods based on such source inspection and/or testing must be made prior to shipment of the Goods.

10. EXPORT COMPLIANCE; FOREIGN CORRUPT PRACTICES ACT

For any resale, export, or re-export of the Goods, Buyer must comply with all applicable export regulations, export licensing requirements, and the United States Foreign Corrupt Practices Act (FCPA), 15 U.S.C. §§ 78dd1 through 78dd3, as amended.

11. DELIVERY SCHEDULES AND FORCE MAJEURE

Shipping dates are approximate and require prompt receipt of all necessary Buyer-furnished information and material if applicable.

Seller is not liable for any damages, re-procurement costs, or penalties related to late deliveries. Without limiting the generality of the foregoing, Seller is not liable for delays due to force majeure, including, but not limited to, weather conditions, acts of God, acts of civil or military authorities, fires, strikes, job actions, floods, earthquakes, epidemics, quarantine restriction, war, terrorism, riot, supplier or vendor delays, or any other causes beyond the reasonable control of Seller. In the event of such delay, Seller will promptly notify Buyer and the date(s) of delivery will be deferred for a period commensurate with the time lost due to the delay. If the excusable delay under force majeure continues for more than ninety (90) days, Seller and Buyer will each have the option of terminating the affected Order(s) under Article 12, Termination for Convenience. If Seller's production is curtailed for any of the above reasons so that Seller is unable to deliver the full quantity of Goods scheduled for delivery to Buyer, Seller may allocate deliveries of available Goods among its various customers then under order for similar Goods. The allocation will be made in a commercially fair and reasonable manner. When such allocation has been made, Buyer will be notified of the estimated quota made available.

12. TERMINATION FOR CONVENIENCE

Buyer may request to terminate Buyer's Order for convenience in whole or in part and Seller agrees to cooperate with Buyer in attempting to make such arrangements conditioned on Buyer paying Seller for all deliveries made and for all work in process, including all applicable direct and indirect costs, settlements with suppliers, and related administrative, accounting, and legal costs, plus a normal profit. To the extent possible, Seller will use reasonable commercial efforts to divert materials and work in process from Buyer's Order to other customers' orders in order to minimize Buyer's termination costs.

Miscellaneous

13. TERMINATION FOR DEFAULT

Either Party may terminate the Order if the other Party breaches a material provision of this Agreement or of the Order. In the event that a Party (the "Defaulting Party") is in breach of a material provision of this Agreement or the Order, the other Party (the "Non-Defaulting Party") will submit a written cure notice to the Defaulting Party advising of such breach. The Defaulting Party will have fifteen (15) days to cure the breach. If the Defaulting Party does not cure the breach within the fifteen (15) day period, the Non-Defaulting Party may terminate the Order.

14. CHANGES ORDERS AND AMENDMENTS

All change order requests must be submitted by the Buyer to the Seller in writing and will not be effective unless and until Seller consents in writing to the change(s). Seller will advise Buyer in writing of the price and/or delivery schedule impact, if any, of the change request. Seller's acceptance of changes will be subject to Buyer's agreement to any price and/or delivery schedule adjustments.

15. LIMITED WARRANTY

Seller warrants that the Goods manufactured by Seller will be free from defects in material and workmanship for a period of twelve (12) months from the date of original shipment, except for components and consumables that have shorter third party manufacturer's warranty periods. Components and consumables manufactured by third parties will bear the warranty of their manufacturer.

The specific warranty for a given product is the one in effect on the date of shipment. In the event that Buyer identifies any defects in material or workmanship, Buyer will promptly notify Seller of the defective Goods and the specific nature of the defect in accordance with Article 16, Return Authorizations.

Seller, at its sole discretion, will either repair or replace any such Goods found by Seller to be defective. Seller's warranty does not apply to any Goods that have been subjected to improper installation, misuse, alteration, repair, neglect, accident, inundation, fire, or the like.

THESE EXPRESS WARRANTIES, INCLUDING REMEDIES, ARE EXCLUSIVE AND ARE IN LIEU OF ANY AND ALL OTHER WARRANTIES, EXPRESS OR IMPLIED. NO WARRANTY OF MERCHANTABILITY OR FITNESS FOR A PARTICULAR PURPOSE IS INTENDED OR GIVEN. IN THE CASE OF GOODS OTHER THAN THOSE OF SELLER'S OWN MANUFACTURE, SELLER MAKES NO WARRANTIES, EXPRESS, STATUTORY, OR IMPLIED.

16. RETURN AUTHORIZATIONS

Buyer will promptly notify Seller of any nonconformance(s) in the Goods and afford Seller a reasonable opportunity to inspect the Goods. No Goods may be returned without Seller's prior authorization, as evidenced by a return authorization. Once a return authorization number is obtained, Buyer will return defective Goods transportation and insurance prepaid in accordance with instructions issued by Seller. Failure to follow Seller's return procedures may result in lost Goods, delays, additional service, restocking charges, warranty denial, or refusal of a shipment. The return authorization number must appear on the shipping label along with all paperwork associated with the return. Seller has the right to reject Goods returned without the correct return authorization number clearly marked on the outside of the shipping container. Granting a return authorization number does not necessarily mean that a credit will be approved or that the evaluation or repair will take place without a fee.

17. INDEMNIFICATION

Each Party (the "Indemnifying Party") will hold harmless and indemnify the other Party (the "Indemnitee") against all claims, judgments, costs, and fees, including attorney fees, relating to infringement of U.S. patents, designs, copyrights, or trademarks to the extent that the infringing Goods are manufactured, sold, or used in whole or in part to the Indemnifying Party's specifications, designs, drawings, or other technical data.

To the extent that one Party's employees or agents enter on the property owned or controlled by the other Party, the first Party will indemnify and hold harmless the other Party, its officers, directors, and employees for any property damage or bodily injury or death caused by the first Party's employees or agents.

18. LIMITATION OF LIABILITY

NOTWITHSTANDING ANY OTHER PROVISIONS OF THIS AGREEMENT, UNDER NO CIRCUMSTANCES IS EITHER PARTY LIABLE FOR ANY CONSEQUENTIAL, SPECIAL, INCIDENTAL, INDIRECT, MULTIPLE, ADMINISTRATIVE, OR PUNITIVE DAMAGES, OR ANY DAMAGE OF AN INDIRECT OR CONSEQUENTIAL NATURE ARISING OUT OF OR RELATED TO ITS PERFORMANCE UNDER THIS AGREEMENT, WHETHER BASED UPON BREACH OF THIS AGREEMENT, WARRANTY, OR NEGLIGENCE AND WHETHER GROUNDED IN TORT, CONTRACT, CIVIL LAW, OR OTHER THEORIES OF LIABILITY, INCLUDING STRICT LIABILITY, EVEN IF ADVISED IN ADVANCE OF THE POSSIBILITY OF SUCH DAMAGES. SELLER'S TOTAL LIABILITY INCLUDING, BUT NOT LIMITED TO, LIABILITY FOR INDEMNITY, DEFENSE, AND HOLD HARMLESS OBLIGATIONS IS LIMITED TO NO MORE THAN THE AMOUNT PAID TO SELLER UNDER BUYER'S ORDER AND BUYER AGREES TO INDEMNIFY SELLER FOR ANY EXCESS AMOUNTS. TO THE EXTENT THAT THIS LIMITATION OF LIABILITY CONFLICTS WITH ANY OTHER PROVISION(S) OF THIS AGREEMENT, SUCH PROVISION(S) WILL BE REGARDED AS AMENDED TO WHATEVER EXTENT REQUIRED TO MAKE SUCH PROVISION(S) CONSISTENT WITH THIS PROVISION.

19. ARBITRATION AND LAW

Disputes that arise under this Agreement or Buyer's Order that cannot be settled amicably by the Parties will be settled by arbitration in Boston, Massachusetts, United States of America under the prevailing rules of the commercial conciliation and arbitration rules of the American Arbitration Association. Judgment upon the arbitration award or decision may be entered in any court of competent jurisdiction. Arbitration awards and decisions are subject to Article 18, Limitation of Liability.

The laws of the State of Massachusetts excluding its conflicts of laws provisions and excluding the United Nations Convention on the International Sale of Goods ("CISG"), govern the interpretation and enforcement of this Agreement and Buyer's Order.

20. ASSIGNMENT

Buyer may not assign or transfer this Agreement or any Order, in whole or in part, without the prior written approval of Seller.

21. ETHICS AND VALUES

Seller is committed to uncompromising ethical standards, strict adherence to law, and customer satisfaction. Buyer is encouraged to communicate any concerns or questions regarding the ethics and value to the Teledyne Corporate Ethics Help Line, "Take the Right Action", at 1-877-666-6968.

22. UNENFORCEABLE PROVISIONS

In the event that one or more provisions of this Agreement document is held to be unenforceable, the remaining provisions apply in full and the invalid or unenforceable provision will be replaced by a provision that lawfully enforces the Parties' intention underlying the invalid or unenforceable provision.

23. SURVIVAL

The following Articles will survive the termination or expiration of this Agreement or any Order: 1: Definitions; 4: Credit Approval and Payment; 5: Taxes; 6: Shipping Terms and Risk of Loss; 7: Tooling; 9: Inspection and Tests; 10: Export Compliance; Foreign Corrupt Practices Act; 11: Delivery Schedules and Force Majeure; 12: Termination for Convenience; 13: Termination for Default; 15: Limited Warranty; 17: Indemnification; 18: Limitation of Liability; 19: Arbitration and Law; 20: Assignment; 22: Unenforceable Provisions; and 23: Survival.

24. WHOLE AGREEMENT; AMENDMENT

This document is the entire understanding between the Parties, and it supersedes all previous or additional agreements, arrangements, and drafts. This document may be amended or modified only by written agreement of duly authorized representatives of both Parties.



TELEDYNE BENTHOS • A MEMBER OF TELEDYNE MARINE

49 Edgerton Drive, North Falmouth, MA 02556 USA

Tel +1 508.563.1000 • Fax +1 508.563.6444 • E-mail: benthos@teledyne.com

Specifications and pricing subject to change without notice. 12/2009. ©2009 TELEDYNE BENTHOS, Inc. Other products and company names mentioned herein may be trademarks and/or registered trademarks.

Rev 121409